



**INTERCONNECTION
FACILITIES STUDY
REPORT**

GEN-2017-172

Published April 2023

By SPP Generator Interconnections Dept.

REVISION HISTORY

DATE OR VERSION NUMBER	AUTHOR	CHANGE DESCRIPTION
04/12/2023	SPP	Initial draft report issued.
05/02/2023	SPP	Updated upgrade information and cost for UIDs 156445 & 156471 in Table 3.
06/08/2023	SPP	Updated upgrade information and cost for UID 143437 in Table 1.
06/21/2023	SPP	Final report issued.
06/28/2023	SPP	Cost revisions made for UIDs 143434 and 156858 in Table 3.
06/28/2024	SPP	Upgrades revised to reflect latest study.

CONTENTS

Revision History	i
Summary	1
Introduction	1
Phase(s) of Interconnection Service	1
Compensation for Amounts Advanced for Network Upgrade(s).....	1
Interconnection Customer Interconnection Facilities	2
Transmission Owner Interconnection Facilities and Non-Shared Network Upgrade(s).....	3
Shared Network Upgrade(s)	4
Contingent Network Upgrade(s).....	5
Affected System Upgrade(s)	6
Conclusion.....	7
Appendices	8
A: Transmission Owner’s Interconnection Facilities Study Report and Network Upgrades Report(s).....	9

SUMMARY

INTRODUCTION

This Interconnection Facilities Study (IFS) for Interconnection Request is for a 50 MW generating facility located in Stephen County, OK. The Interconnection Request was studied in the DISIS-2017-002 Impact Study for ERIS. The Interconnection Customer's requested in-service date is December 01, 2025.

The interconnecting Transmission Owner, American Electric Power Co. (AEP), performed a detailed IFS at the request of SPP. The full report is included in Appendix A. SPP has determined that full Interconnection Service will be available after the assigned Transmission Owner Interconnection Facilities (TOIF), Non-Shared Network Upgrades, Shared Network Upgrades, Contingent Network Upgrades, and Affected System Upgrades that are required for full interconnection service are completed.

The primary objective of the IFS is to identify necessary Transmission Owner Interconnection Facilities, Network Upgrades, other direct assigned upgrades, cost estimates, and associated upgrade lead times needed to grant the requested Interconnection Service.

PHASE(S) OF INTERCONNECTION SERVICE

It is not expected that Interconnection Service will occur in phases. However, full Interconnection Service will not be available until all Interconnection Facilities and Network Upgrade(s) can be placed in service.

COMPENSATION FOR AMOUNTS ADVANCED FOR NETWORK UPGRADE(S)

FERC Order ER20-1687-000 eliminated the use of Attachment Z2 revenue crediting as an option for compensation. The Incremental Long Term Congestion Right (ILTCR) process will be the sole process to compensate upgrade sponsors as of July 1st, 2020.

INTERCONNECTION CUSTOMER INTERCONNECTION FACILITIES

The Generating Facility is proposed to consist of (28) 2.0 MVA inverters for a total generating nameplate capacity of 50 MW.

The Interconnection Customer's Interconnection Facilities to be designed, procured, constructed, installed, maintained, and owned by the Interconnection Customer at its sole expense include:

34.5 kV underground cable collection circuits;

34.5 kV to 345 kV transformation substation with associated 34.5 kV and 345 kV switchgear;

One 345/34.5 kV 36/48/60 MVA (ONAN/ONAF/ONAF) step-up transformer to be owned and maintained by the Interconnection Customer at the Interconnection Customer's substation;

Approx. 0.18 mile 345 kV line to connect the Interconnection Customer's substation to the Point of Interconnection ("POI") at the 345 kV bus at existing Transmission Owner substation ("Lawton Eastside - Terry Road 345kV") that is owned and maintained by Transmission Owner;

All transmission facilities required to connect the Interconnection Customer's substation to the POI;

Equipment at the Interconnection Customer's substation necessary to maintain a composite power delivery at continuous rated power output at the high-side of the generator substation at a power factor within the range of 95% lagging and 95% leading in accordance with Federal Energy Regulatory Commission (FERC) Order 827. The Interconnection Customer may use inverter manufacturing options for providing reactive power under no/reduced generation conditions. The Interconnection Customer will be required to provide documentation and design specifications demonstrating how the requirements are met; and,

All necessary relay, protection, control and communication systems required to protect Interconnection Customer's Interconnection Facilities and Generating Facilities and coordinate with Transmission Owner's relay, protection, control and communication systems.

TRANSMISSION OWNER INTERCONNECTION FACILITIES AND NON-SHARED NETWORK UPGRADE(S)

To facilitate interconnection, the interconnecting Transmission Owner will perform work as shown below necessary for the acceptance of the Interconnection Customer’s Interconnection Facilities.

Table 1 and **Table 2** lists the Interconnection Customer’s estimated cost responsibility for Transmission Owner Interconnection Facilities (TOIF) and Non-Shared Network Upgrade(s) and provides an estimated lead time for completion of construction. The estimated lead time begins when the Generator Interconnection Agreement has been fully executed.

Table 1: Transmission Owner Interconnection Facilities (TOIF)

Transmission Owner Interconnection Facilities (TOIF)	Total Cost Estimate (\$)	Allocated Percent (%)	Allocated Cost Estimate (\$)	Estimated Lead Time
<u>Lawton Eastside - Terry Road 345kV GEN-2017-172 Interconnection (TOIF) (AEP) (143437)</u> ; Interconnection upgrades and cost estimates needed to interconnect the following Interconnection Customer facility, GEN-2017-172 (50 MW/Solar), into the Point of Interconnection (POI) at Lawton Eastside - Terry Road 345kV	\$3,876,319	20%	\$775,264	36 Months
Total	\$3,876,319		\$775,264	

Table 2: Non-Shared Network Upgrade(s)

Non-Shared Network Upgrades Description	ILTCR	Total Cost Estimate (\$)	Allocated Percent (%)	Allocated Cost Estimate (\$)	Estimated Lead Time
<u>NA</u>	NA	NA	NA	NA	NA
Total		NA		NA	

SHARED NETWORK UPGRADE(S)

The Interconnection Customer’s share of costs for Shared Network Upgrades is estimated in **Table 3** below.

Table 3: Interconnection Customer Shared Network Upgrade(s)

Shared Network Upgrades Description	ILTCR	Total Cost Estimate (\$)	Allocated Percent (%)	Allocated Cost Estimate (\$)	Estimated Lead Time
<u>Lawton Eastside - Terry Road 345kV New Interconnection Substation (DISIS-2017-002)(143434):</u> <u>Construct a new Lawton Eastside - Terry Road 345kV substation to accommodate the interconnection of GEN-2017-171, GEN-2017-172, and GEN-2017-173</u>	Ineligible	\$18,137,968	20%	\$3,627,594	36 Months
Total		\$18,137,968		\$3,627,594	

All studies have been conducted assuming that higher-queued Interconnection Request(s) and the associated Network Upgrade(s) will be placed into service. If higher-queued Interconnection Request(s) withdraw from the queue, suspend or terminate service, the Interconnection Customer’s share of costs may be revised. Restudies, conducted at the customer’s expense, will determine the Interconnection Customer’s revised allocation of Shared Network Upgrades.

CONTINGENT NETWORK UPGRADE(S)

Certain Contingent Network Upgrades are **currently not the cost responsibility** of the Interconnection Customer but will be required for full Interconnection Service.

Table 4: Interconnection Customer Contingent Network Upgrade(s)

Contingent Network Upgrade(s) Description	Current Cost Assignment	Estimated In-Service Date
<u>NTC 210627- Multi - Border - Woodward 345 kV Tap (122796/122823/14382)</u> : Build 0.84-miles of new 345 kV line from a new tap on the Woodward to Border 345 kV line to Chisholm	\$0	3/31/2025

Depending upon the status of higher- or equally-queued customers, the Interconnection Request’s in-service date is at risk of being delayed or Interconnection Service is at risk of being reduced until the in-service date of these Contingent Network Upgrades.

AFFECTED SYSTEM UPGRADE(S)

To facilitate interconnection, the Affected System Transmission Owner will be required to perform the facilities study work as shown below necessary for the acceptance of the Interconnection Customer’s Interconnection Facilities. **Table 5** displays the current impact study costs provided by either MISO or AECI as part of the Affected System Impact review. The Affected System facilities study could provide revised costs and will provide each Interconnection Customer’s allocation responsibilities for the upgrades.

Table 5: Interconnection Customer Affected System Upgrade(s)

Affected System Upgrades Description	Total Cost Estimate (\$)	Allocated Percent (%)	Allocated Cost Estimate (\$)
<u>NA</u>	NA	NA	NA
Total	NA		NA

CONCLUSION

After all Interconnection Facilities and Network Upgrades have been placed into service, Interconnection Service for MW can be granted. Full Interconnection Service will be delayed until the TOIF, Non-Shared NU, Shared NU, Contingent NU, Affected System Upgrades that are required for full interconnection service are completed. The Interconnection Customer's estimated cost responsibility for full interconnection service is summarized in the table below.

Table 6: Cost Summary

Description	Allocated Cost Estimate
Transmission Owner Interconnection Facilities Upgrade(s)	\$775,264
Non-Shared Network Upgrade(s)	\$0
Shared Network Upgrade(s)	\$3,627,594
Affected System Upgrade(s)	\$0
Total	\$4,402,858

Use the following link for Quarterly Updates on upgrades from this report: <https://spp.org/spp-documents-filings/?id=18641>

A draft Generator Interconnection Agreement will be provided to the Interconnection Customer consistent with the final results of this IFS report. The Transmission Owner and Interconnection Customer will have 60 days to negotiate the terms of the GIA consistent with the SPP Open Access Transmission Tariff (OATT).

APPENDICES

**A: TRANSMISSION OWNER'S INTERCONNECTION FACILITIES STUDY
REPORT AND NETWORK UPGRADES REPORT(S)**

See next page for the Transmission Owner's Interconnection Facilities Study Report and Network Upgrades Report(s).



**AEP Generation Interconnection
Facilities Study Report**

for

DISIS 2017-002

**GEN-2017-171, GEN-2017-172, and GEN-
2017-173**

**345 kV Lawton Eastside-Terry Road
transmission line**

Stephens County, Oklahoma

1 Facilities Study Summary

American Electric Power (AEP) Southwest Transmission Planning performed the following study at the request of the Southwest Power Pool (SPP) for SPP Generation Interconnection request DISIS-2017-002, GEN-2017-171, GEN-2017-172, and GEN-2017-173. Per the SPP Generator Interconnection Procedures (GIP), SPP requested that AEP perform an Interconnection Facilities Studies (IFS) for Network Upgrade(s) in accordance with Section 8.11 for the following Interconnection and/or Network Upgrade(s):

1.1 Project Description

GEN-2017-171, GEN-2017-172, and GEN-2017-173 proposes to install a 250 MW solar generating facility in Stephens County, Oklahoma (Figure 2). The point of interconnection for the generating facility will be AEP's 345 kV Lawton Eastside – Terry Road transmission line (Figure 1).

1.2 AEP's Scope of Work to Facilitate Interconnection

- To accommodate the interconnection to AEP's existing 345 kV Lawton Eastside – Terry Road transmission line, a new 345 kV, 3-breaker ring bus station will be installed. Also, AEP will complete any needed remote work at the 345 kV Lawton Eastside and Terry Road stations associated with this project. The design and construction of the new station will meet all AEP specifications. Bus work and disconnect switches will be designed to accommodate the loading requirements, and circuit breakers will be rated to ensure adequate load and fault interrupting capability. AEP will own, operate and maintain the new 345 kV ring bus station.
- Installation of associated protection and control equipment, SCADA, and revenue metering will be required at the new 345 kV ring bus station. AEP reserves the right to specify the final acceptable configuration considering design practices, future expansion, and compliance requirements.
- AEP will extend one span of 345 kV transmission line from the generator's terminal at new 345 kV ring bus station to the GEN-2017-171, GEN-2017-172, and GEN-2017-173 POI. AEP will build and own the first transmission line structure outside of new 345 kV ring bus station, to which AEP's transmission line conductor will attach. Right of Way (ROW) will be required for this span.

- It is understood that the Interconnection Customer is responsible for all of the connection costs associated with interconnecting GEN-2017-171, GEN-2017-172, and GEN-2017-173 to the AEP transmission system. The cost of the customer’s generating facility and the costs for the line connecting the generating facility to AEP’s transmission system (Beyond the first span exiting the POI) are not included in this report; these are assumed to be the Customer’s responsibility.
- The customer will be responsible for the cost of constructing a fiber-optic connection from their telecom equipment to AEP’s new 345 kV ring bus station’s.

1.3 Short Circuit Evaluation

- It is standard practice for AEP to recommend replacing a circuit breaker when the current through the breaker for a fault exceeds 100% of its interrupting rating with recloser de-rating applied, as determined by the ANSI/IEEE C37.5-1979, C37.010-1979 & C37.04-1979 breaker rating methods.
- In the AEP system, no breakers were found to exceed their interrupting capability after the addition of the generation and related facilities. Therefore, there are no additional short circuit upgrade costs associated with the DISIS-2017-002, GEN-2017-171, GEN-2017-172, and GEN-2017-173 interconnection.

1.4 Stability Evaluation

Based on the results of the 2017-002 DISIS short circuit and stability report, AEP is not aware of any instances where the system does not meet TPL-001 stability performance requirements for the planning events and generation dispatch conditions that were considered in this DISIS study.

1.5 Interconnection Cost of Facilities Included in the Facilities Study:

Network Upgrades (Install 3-breaker ring bus and associated work)	\$17,851,666
Transmission Owner Interconnection Facilities (TOIF)(GEN-2017-171, GEN-2017-172, and GEN-2017-173 are combined, sharing one terminal at the AEP station)	\$3,876,319
Remote End Work	\$286,302
Total Cost	\$22,014,287

The estimates do not include the impact that delays in obtaining ROW, permits, or other approvals may have.

1.6 Project Lead time

Project in-service date is projected to be 30 months after the issuance of Authorization to Proceed from the Interconnection Customer.

Figure 1: Point of Interconnection (POI INFORMATION) One-Line Diagram

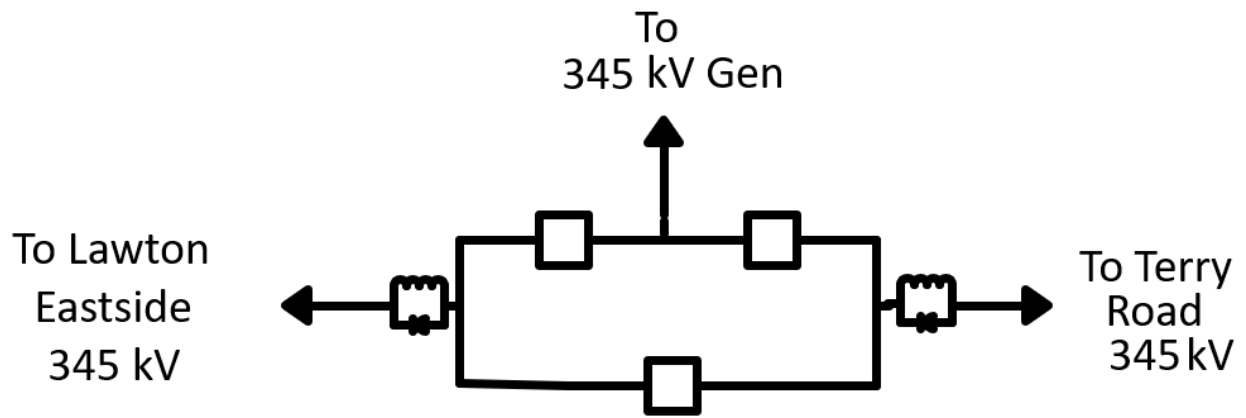

Figure 2: Point of Interconnection Map

